

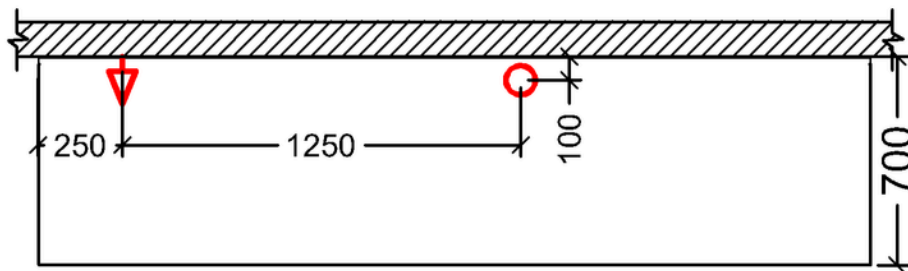

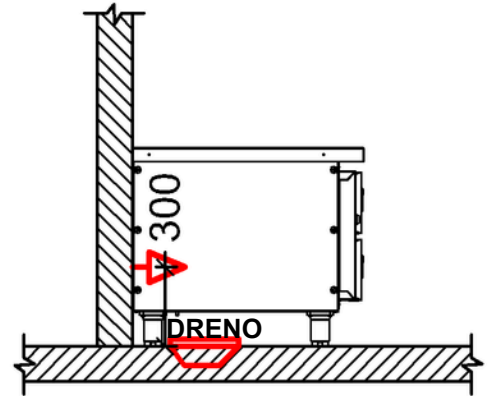

ALFATEC | RHIAA1-4P50 | FICHA TÉCNICA

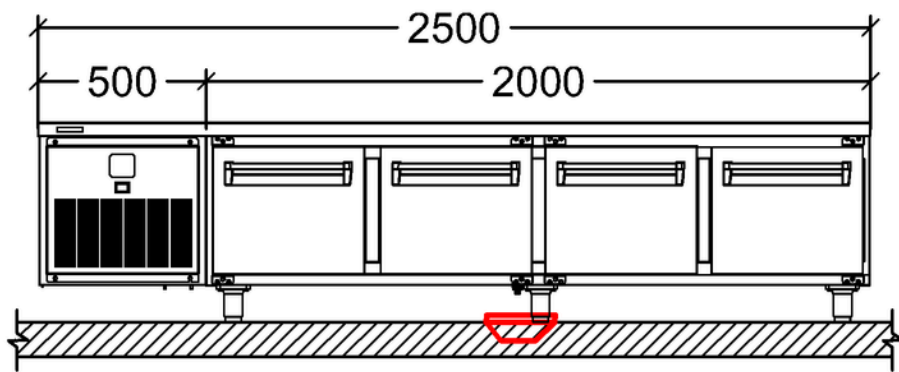







LEGENDA

-  220 Volts 10A- Bif/Mono 650W- H=30cm Tomada tipo "N" 
-  Dreno no piso \varnothing 40mm (Desconsiderar para sistema Frost Free)

OBSERVAÇÕES

- Todas as instalações devem obedecer as normas da ABNT;
- A tomada deve estar dimensionada de acordo com a potência do equipamento;
- Posição de pontos sugeridos;

OPCIONAL

-  CORPO EM AÇO INOX
-  TAMPO EM AÇO INOX
-  PORTAS DE VIDRO COM ILUMINAÇÃO
-  KIT FROST FREE
-  GAVETAS
-  RODÍZIOS

ESPECIFICAÇÕES TÉCNICAS

Medidas :	2500x700x600mm
Medidas com Embalagem:	2900x1000x700mm
Peso :	75,06 kg
Peso com Embalagem:	81,67 kg
Equipamento:	Refrigerador
Temperatura de trabalho:	1°C à 8°C
Potência:	650W
Gás Refrigerante:	R134A
Tensão Elétrica:	220V -60Hz, Mono/Bif.
Capacidade:	390 Litros 0,39 M ³



Rio de Janeiro – matriz e fábrica
Rua Frei Jaboatão, 100 – Bonsucesso
Rio de Janeiro – RJ, 21041-115
Telefone: (21) 2564-2001 / 97021-9982

São Paulo
Telefone: (11) 3230-7656
email: contato@alfatec.ind.br

SOLUÇÕES EM COZINHAS PROFISSIONAIS

 @Alfatec.Cozinhas

 (21) 97215-7105