

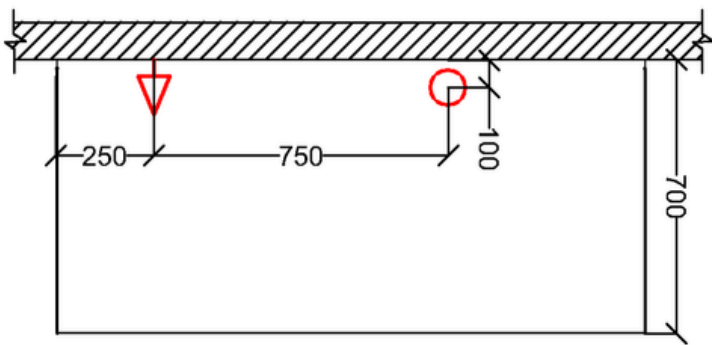

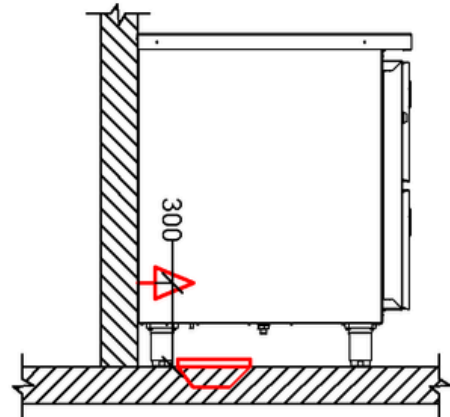

# ALFATEC | RHIA1-4G50 | FICHA TÉCNICA

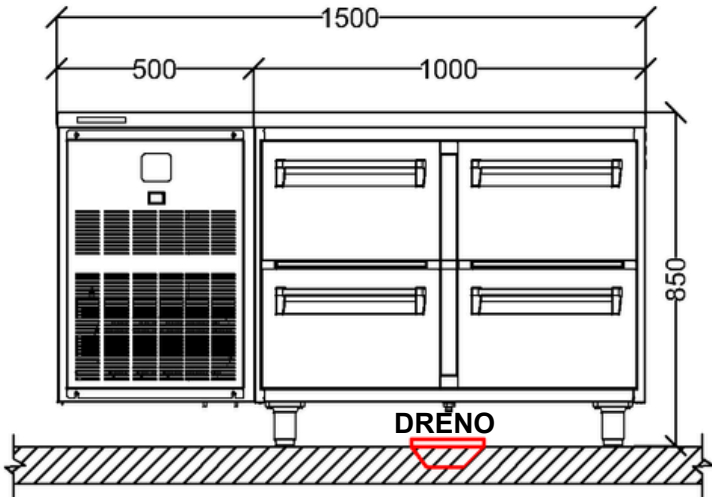

## LEGENDA

-  220 Volts 10A- Bif/Mono 450W- H=30cm Tomada tipo "N" 
-  Dreno no piso  $\varnothing$  40mm (Desconsiderar para sistema Frost Free)

## OBSERVAÇÕES

- Todas as instalações devem obedecer as normas da ABNT;
- A tomada deve estar dimensionada de acordo com a potência do equipamento;
- Posição de pontos sugeridos;

## OPCIONAL

-  RODÍZIOS
-  KIT FROST FREE
-  TAMPO EM AÇO INOX

## ESPECIFICAÇÕES TÉCNICAS

Medidas :	1500x700x850mm
Medidas com Embalagem:	1700x1000x890mm
Peso :	67,06 kg
Peso com Embalagem:	72,61 kg
Equipamento:	Refrigerador
Temperatura de trabalho:	1°C à 8°C
Potência:	450W
Gás Refrigerante:	R134A
Tensão Elétrica:	220V -60Hz, Mono/Bif.
Capacidade:	GN 1/1X100 p/GAV.



Rio de Janeiro – matriz e fábrica  
Rua Frei Jaboatão, 100 – Bonsucesso  
Rio de Janeiro – RJ, 21041-115  
Telefone: (21) 2564-2001 / 97021-9982

São Paulo  
Telefone: (11) 3230-7656  
email: contato@alfatec.ind.br

 **ALFATEC**  
SOLUÇÕES EM COZINHAS PROFISSIONAIS

 @Alfatec.Cozinhas

 (21) 97215-7105